

IntelliGen® ULV Dispense System

Advanced two-stage system enabling superior dispense and filtration of low-viscosity fluids

Building on the proven performance of the two-stage dispense technology combined with Entegris' innovative Connectology® filter design, IntelliGen® ULV dispense system integrates high-purity filtration with repeatable dispense of low-viscosity fluids (1 – 100 cP or at higher viscosities when dispense pressure does not exceed 29 psi). An optional post-cleaning technology provides a sanitized system that can dispense a more uniform topography of photochemical onto the wafer during the lithography coating process. It also helps to shorten start-up times and provides intelligent dispense diagnostics. The compatible Impact® 8G or Impact 2 V2 (OF style) filter easily slides into the IntelliGen ULV system. Fluid passes through the Impact filter at the optimum flow rate for the specified retention rating, improving throughput, and increasing uptime.

The integrated, dual pressure sensor provides real-time alerts and enhances filter priming by providing several confirmation features including, dispense confirmation, cycle time confirmation, and delta P confirmation. This helps to prevent costly wafer defects due to coating problems as well as random DC error occurrences triggered by backlash issues at lower ready pressure levels. The state-of-the-art air detection feature pinpoints when air enters the outlet tubing from a leak or from minute air bubbles that gradually accumulate over time. The compact design, superior performance, and interactive diagnostics make the IntelliGen ULV dispense system the right choice for low-viscosity photoresist applications, ensuring dispense repeatability, longer filter life, and a greater return on investment.



Leading-edge, two-stage system with built in dual PT sensors enables independent, repeatable dispense and high-purity filtration.

FEATURES & BENEFITS

Two-stage dispense technology with Connectology filter design	<p>Integrates high-purity filtration with excellent dispense repeatability of low-viscosity fluids (1–100 cP or higher viscosities when dispense pressure does not exceed 29 psi)</p> <p>Independently optimized dispense and filtration sequences</p> <p>Advanced closed-loop software control with several additional fault detection features</p> <p>Integrates with Impact 8G or Impact V2 (OF style)</p> <ul style="list-style-type: none">• Slides into ULV compartment for bubble, gel and particle removal
Built-in technology enhancements – PCB and dual sensors added	<p>Enhanced filtration control</p> <p>Expandable capabilities without memory limitations</p> <p>Extension of confirmation tools</p> <ul style="list-style-type: none">• Delta P <p>Better startup and filter priming technology</p> <p>Real-time clock technology with traceability</p>
More reliable dispense settings	<p>Ball screw incorporated into dispense motor</p> <p>Lower ready pressure setting available</p>
Improved chemical turnover technology	<p>Chamber design facilitates chemical turnover</p> <p>Adjustable fill chamber reduces hold-up volume</p> <p>Valve design more effectively clears contaminants</p>
Optional enhancements	<p>Unique post-cleaning technology enables a more uniform photochemical coating</p> <p>Flowmeter RSQ confirmation</p> <ul style="list-style-type: none">• Finer one-shot volume detection• Microbubble detection

SPECIFICATIONS

Dispense performance	Volume	0.01 – 10.0 mL in 0.001 mL increments
	Rate	0.01 – 3.0 mL/sec in 0.001 mL/sec increments
	Repeatability	≤0.02 mL 3 sigma
	Viscosity range*	1 – 100 cP
	Maximum dispense design pressure**	0.21 MPa (30 psi)
Recharge performance	Fill rate, filtration rate, vent rate, purge rate	0.1 – 3.0 mL/sec in 0.001 mL/sec increments
	Vent frequency	Auto-venting or 1 – 10,000 dispense cycles
Mechanical	Wetted surfaces	Modified PTFE, PTFE, Kalrez®
	Connection type	Insert style, Super Type Pillar® or Flowell™ 60 series
	Filter	Impact 8G or Impact 2 V2 (OF style)
	Inlet, outlet and vent tubing	OD: 6.35 mm (0.25") or 6.0 mm (0.24") ID: 3.97 mm (0.15628") or 4.0 mm (0.16")
	Inlet gas type	Regulated N ₂
	Operating conditions	Minimum operating pneumatic pressure: 0.26 MPa (38 psi) Maximum operating pneumatic pressure: 0.28 MPa (40 psi) Pneumatic leak pressure: 0.30 MPa (43 psi)
	Vacuum	-68 kPa (20 in -Hg min.)
Dimensions	Height	200.1 mm (7.878")
	Width	60.7 mm (2.39")
	Depth	216.5 mm (8.52")
Weight	Approximately 5 kg (11 lb)	
Electrical	Current rating	1.25A maximum
	Input voltage (system)	24 VDC ±10%
	Serial communication	Specifications are dependent on interface module use
	Parallel communication	Triggers and acknowledgments
Certifications	See provided documentation	
Environment	Indoor use only	
	Altitude below 2000 m (2187.22 yd)	
	Ambient temperature 5° – 40°C (41° – 104°F)	
	Maximum relative humidity 80% for temperatures up to 31°C (88°F) decreasing linearly to 50% relative humidity at 40°C (104°F)	
	Mains supply fluctuations from 22 – 26 VDC	
	Transient overvoltages of overvoltage category II	
Pollution degree 2		

*Depends on tool configuration. Contact applications support for detailed window of operation.

**Maximum pressure is a limit on the Window of Operation. Actual volumes and rates may be restricted to comply with the pressure limits for a given viscosity, tubing diameter, tubing length, and tubing height.

PERFORMANCE DATA

This graph shows dispense repeatability trending over a span of 200 dispense cycles at a dispense rate of 1.0 mL/sec.

IntelliGen ULV Dispense Repeatability
1.3 cP Fluid at 1.0 mL/sec Dispense Rate

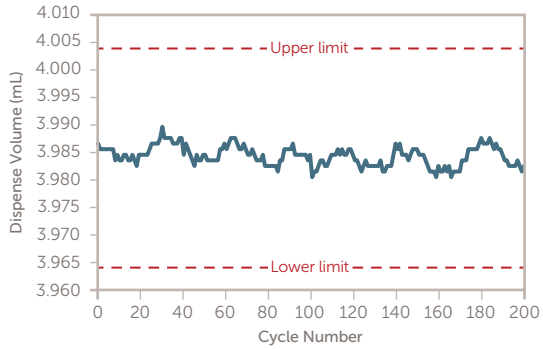

DIMENSIONS

The following drawings show dimensions for all available IntelliGen ULV fitting configurations.

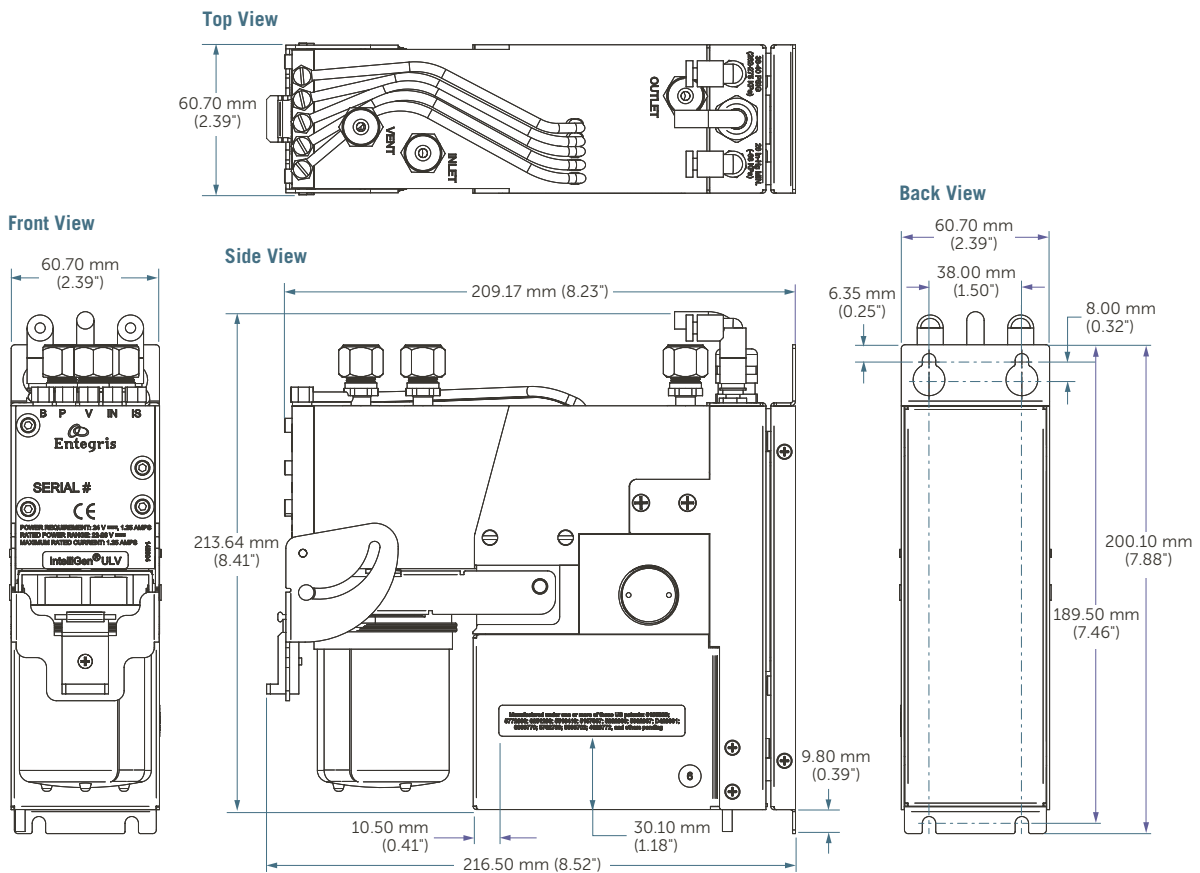

ORDERING INFORMATION

The following table lists the IntelliGen ULV dispense system, vertical style part numbers.

Part number	Fitting type	Cable length	Cable connector	Post cleaning (OK73 thinner flushing)
IGULVPVAP1	¼" Super Type Pillar	3.0 m (9.84')	D-Sub 15 pin	N/A
IGULVPVAP1F1	¼" Super Type Pillar	3.0 m (9.84')	D-Sub 15 pin	1000 times flushing
IGULVPVAP1F6	¼" Super Type Pillar	3.0 m (9.84')	D-Sub 15 pin	6000 times flushing
IGULVPVBP1	¼" Super Type Pillar	1.25 m (4.10')	PA-Con 15 pin	N/A
IGULVPVBP1F1	¼" Super Type Pillar	1.25 m (4.10')	PA-Con 15 pin	1000 times flushing
IGULVPVCP1	¼" Super Type Pillar	0.8 m (2.62')	D-Sub 15 pin	N/A
IGULVPVCP1F1	¼" Super Type Pillar	0.8 m (2.62')	D-Sub 15 pin	1000 times flushing
IGULVPVGP1	¼" Super Type Pillar	0.1 m (0.32')	D-Sub 15 pin, 3 lines	N/A
IGULVPVGP1TD*	¼" Super Type Pillar	0.1 m (0.32')	D-Sub 15 pin, 3 lines	N/A
IGULVPVHP2	6 mm Super Type Pillar	1.25 m (4.10')	D-Sub 15 pin	N/A
IGULVPVJP2	6 mm Super Type Pillar	10 m (32.81')	D-Sub 15 pin	N/A
IGULPVAW1	¼" Flowell 60 series	3.0 m (9.84')	D-Sub 15 pin	N/A
IGULPVAW4	¼" Flowell 60 series (in, out) 4 mm Flowell 60 series (vent)	3.0 m (9.84')	D-Sub 15 pin	N/A
IGULPVAW4F1	¼" Flowell 60 series (in, out) 4 mm Flowell 60 series (vent)	3.0 m (9.84')	D-Sub 15 pin	1000 times flushing
IGULPVAW4F6	¼" Flowell 60 series (in, out) 4 mm Flowell 60 series (vent)	3.0 m (9.84')	D-Sub 15 pin	6000 times flushing
IGULPVAW4M**	¼" Flowell 60 series (in, out) 4 mm Flowell 60 series (vent)	3.0 m (9.84')	D-Sub 15 pin	N/A

*Thermo device type

**OM filter connection

The following ordering information serves as a guide.

Please contact your local representative to confirm part numbers.

Impact 8G and 8G UC Series Filters: part number

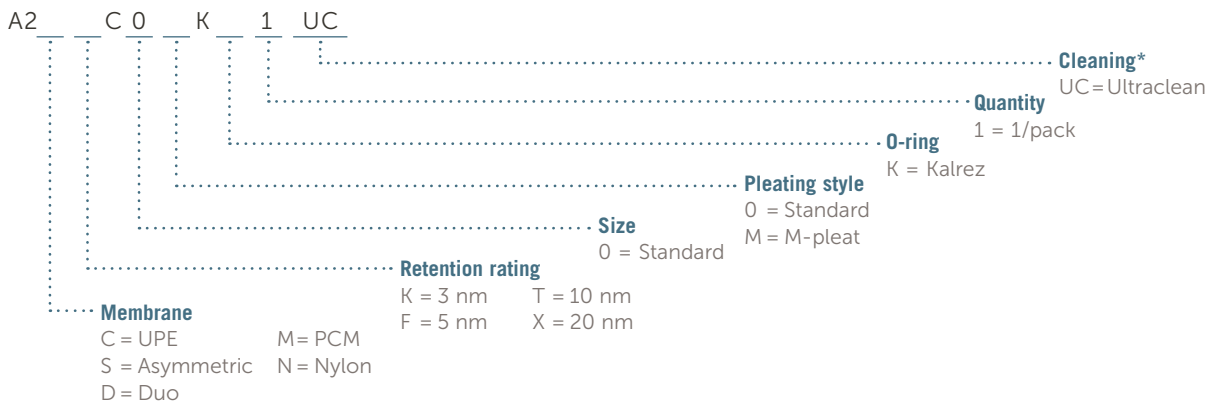

*Cleaning only applies to Impact 8G UC series filters.

Impact 2 V2 Filters: part number

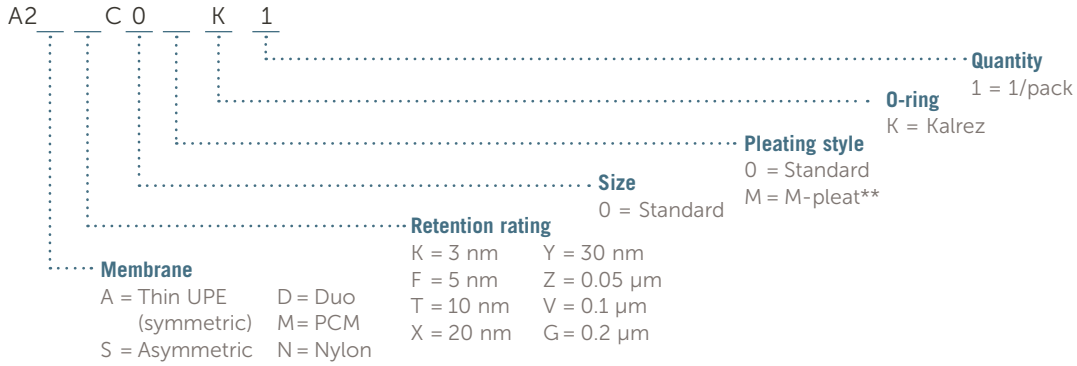

**The M-pleat style only applies to Impact filters with a UPE membrane of up to 30 nm.

FOR MORE INFORMATION

Please call your Regional Customer Service Center today to learn what Entegris can do for you. Visit entegris.com and select the [Contact Us](#) link to find the customer service center nearest you.

TERMS AND CONDITIONS OF SALE

All purchases are subject to Entegris' Terms and Conditions of Sale. To view and print this information, visit entegris.com and select the [Terms & Conditions](#) link in the footer.



Corporate Headquarters
129 Concord Road
Billerica, MA 01821
USA

Customer Service
Tel +1 952 556 4181
Fax +1 952 556 8022
Toll Free 800 394 4083

Entegris®, the Entegris Rings Design®, and other product names are trademarks of Entegris, Inc. as listed on entegris.com/trademarks. All third-party product names, logos, and company names are trademarks or registered trademarks of their respective owners. Use of them does not imply any affiliation, sponsorship, or endorsement by the trademark owner.

©2016-2019 Entegris, Inc. | All rights reserved. | Printed in the USA | 3811-8036ENT-0719